

Benutzung
Use
Utilisation
Utilizzazione
Uso
Gebruik
Användning
Käyttö
Bruk
Brug

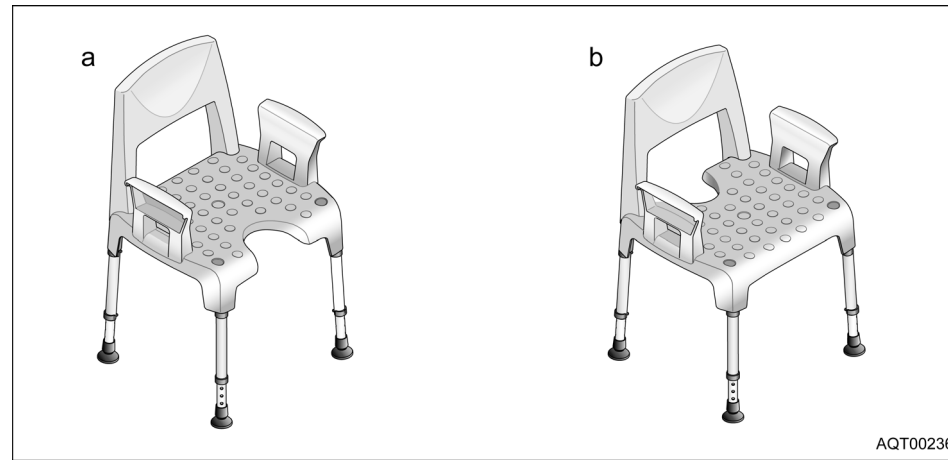

AQT00236

Reinigen
Cleaning
Nettoyage
Pulizia
Limpieza
Reinigen
Rengöra
Puhdistaminen
Rengjøring
Rengøring



Ohne Scheuermittel reinigen
Clean without scouring agent
Ne pas utiliser de produits récurrents pour le nettoyage
Non pulirlo con prodotti abrasivi
No utilizar productos abrasivos para su limpieza
Zonder schuurmiddelen reinigen
Använd inte skurmedel
Puhdista ilman hankausaineita
Bruk ikke skuremiddel ved rengjøring
Vask med ordinært rengjørings- og desinfeksjonsmidler med ph verdi under 7,5, børste og klut
Rengør uden skuremiddel

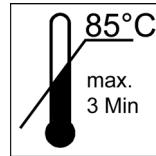

Reinigung mit Hochdruckreiniger erlaubt;
Reinigungstemperatur max. 85 °C für 3 Minuten.
Cleaning with high pressure cleaning device permitted.
Max. cleaning temperature 85 °C for 3 minutes.
Nettoyage avec nettoyeur à haute pression autorisé,
température de nettoyage max. 85 °C pendant 3 minutes.
Per la pulizia è possibile utilizzare un'idropulitrice;
temperatura max. durante la pulizia 85 °C per 3 minuti.
Se autoriza la limpieza con un dispositivo de limpieza de alta presión;
temperatura máx. de limpieza 85 °C durante 3 minutos.
Reinigung met hogedrukreiniger toegestaan,
reinigingstemperatuur max. 85 °C gedurende 3 minuten.
Rengjøring med høytrykksvått er tillåten;
rengjøringstemperatur max. 85 °C under 3 minutter.
Puhdistaminen korkeapainepuhdistimella sallittu;
puhdistuslämpötila maks. 85 °C 3 minuutin ajan.
Kan rengjøres med høytrykksvasker;
rengjøringstemperatur maks. 85 °C i 3 minutter.
Rengøring med højtryksrensere tilladt;
rengøringstemperatur maks. 85 °C i 3 minutter.

CE

Duschhocker
Gebrauchsanweisung

Shower stool
Operating instructions

Tabouret de douche
Mode d'emploi

Sgabello per la doccia
Istruzioni per l'uso

Taburete de ducha
Manual de instrucciones

Douchekruk
Gebruiksaanwijzing

AQUATEC
PICO

Duschpallen
Bruksanvisning

Suihkujakkara
Käyttöohje

Dusjkrakk
Bruksanvisning

Badetaburet
Betjeningsvejledning

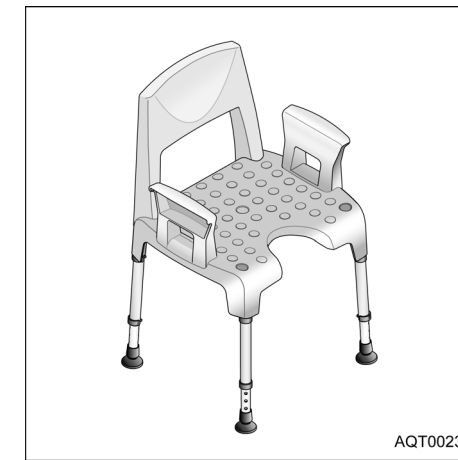

AQT00237

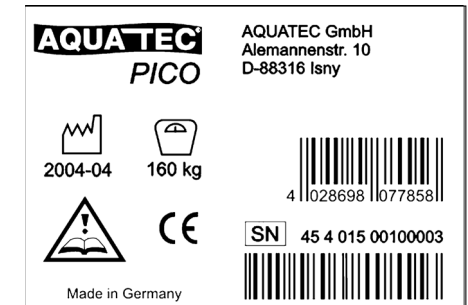

AQT00331

D

AQUATEC GmbH
Alemannenstraße 10
D-88316 Isny
Telefon 07562 700-0
Telefax 07562 700-66
E-Mail info@aquatec.de
Internet www.aquatec.de

F

Invacare® Poirier S.A.S.
Route de St Roch
F-37230 Fondettes
Téléphone 0247 626466
Téléfax 0247 421224
E-mail contactfr@invacare.com
Internet www.invacare.fr

N

Invacare® AS
Grensesvingen 9
N-0603 Oslo
Telefon 22 57 95 00
Telefax 22 57 95 01
E-mail norway@invacare.com
Hjemmeside www.invacare.no

I

Invacare® Mecc San
Via dei Pini, 62
I-36016 Thiene (VI)
Telefono 0445 380059
Telefax 0445 380034
E-mail italia@invacare.com
Internet www.invacare.it

CH

MOBITEC Rehab AG
Bahnhofstrasse 3
CH-5436 Würenlos
Telefon 05640 1520-0
Telefax 05640 1520-1
E-Mail office@mobitec-rehab.ch
Internet www.mobitec-rehab.ch

DK

NEBA AS
Baldersbuen 17, Box 220
DK-2640 Hedehusene
Telefon 046 59 01 77
Telefax 046 59 01 97
E-mail neba@neba.dk
Internet www.neba.dk

NL

RvS Nederland
Bolderweg 6
NL-1332 Almere
Telefoon 036 532 04 50
Fax 036 532 13 08
E-Mail info@rvsnederland.nl
Internet www.rvsnederland.nl

USA

CLARKE HEALTH CARE PRODUCTS Inc.
1003 International Dr.
USA-Oakdale, PA 15071-9226
Telephone 0724 69 52 122
Telefax 0724 69 52 922
E-mail info@clarkehealthcare.com
Internet www.clarkehealthcare.com

A

MOBITEC
Mobilitätshilfen GmbH
Herzog Odilostraße 101
A-5310 Mondsee
Telefon 06232 5535-00
Telefax 06232 5535-4
E-Mail mobitec@nextra.at

S

DOLOMITE AB
Box 55, V. Götgatan 5
S-33421 Anderstorp
Telefon 0371 588400
Telefax 0371 17090
E-Post info@dolomite.se
Hemsida www.dolomite.se

E

Invacare® S.A.
c/Areny
s/n - Poligon Industrial de Celrà
E-17460 Celrà (Girona)
Telefono 972 493200
Telefax 972 493220
E-mail contactsp@invacare.com
Internet www.invacare.es

FIN

Algol Oy
Karapellontie 6
P.O. Box 13
02611 Espoo
Puhelin 09 50991
Fax 09 595 006
E-mail info@algol.fi
Internet www.algol.fi

CDN

Invacare® CANADA INC.
570 Matheson Blvd. E., Unit 8
CDN Mississauga
On. L4Z 4G4
Telephone 0905 8908300
Telefax 0905 8905244
Internet www.invacare.ca

GB

Invacare® Ltd
South Road
Bridgend Industrial Estate
Bridgend
CF31 3PY
Telephone 01656 753200
Telefax 01656 667532
E-mail uk@invacare.com
Internet www.invacare.co.uk

Sicherheitshinweise
Safety instructions
Consignes de sécurité
Indicazioni di sicurezza
Indicaciones de seguridad
Veiligheidsinstructies
Säkerhetsanvisningar
Turvaohjeet
Sikkerhetskshenvisninger
Sikkerhedshenvisninger



Bei Defekt nicht verwenden
Do not use if defective
Ne pas utiliser en cas de défaut
Non impiegarlo se difettoso
No utilizar en malas condiciones
Indien defect niet gebruiken
Använd inte produkten om den är trasig
Älä käytä viallista tuotetta
Må ikke brukes når den er defekt
Må ikke anvendes, hvis den er defekt



Absturzgefahr
Danger of falling
Risque de chute
Pericolo di caduta
Peligro de caída
Gevaar voor vallen
Risk att ramla
Putoamisvaara
Fare for å falle
Fare for at falde ned

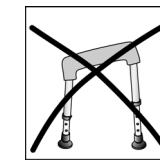

Alle Beine gleiche Höhe
All legs at the same height
Tous les pieds doivent être placés à la même hauteur
Tutte le gambe regolate alla stessa altezza
La misma altura para todas las patas
Alle poten op gelijke hoogte
Alla ben ställs in på samma höjd
Kaikki jalat yhtä korkeita
Alle beina skal ha lik høyde
Alle ben samme højde

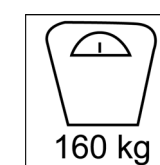

Max. Belastung
Max. load
Charge max.
Portata max.
Carga máx.
Max. belasting
Max. belastning
Maks. kuormitus
Maks. belastning
Maks. belastning

AQT-0015-01-XI

© 2005 AQUATEC GmbH D-88316 Isny
Art.-Nr.: 16510 - Stand 04/05

Lieferumfang
 Scope of delivery
 Volume de livraison
 Fornitura
 Volumen de entrega
 Omvang van de levering
 Leveransomfatning
 Toimituskokonaisuus
 Leveringsomfang
 Indeholdt i leveringen

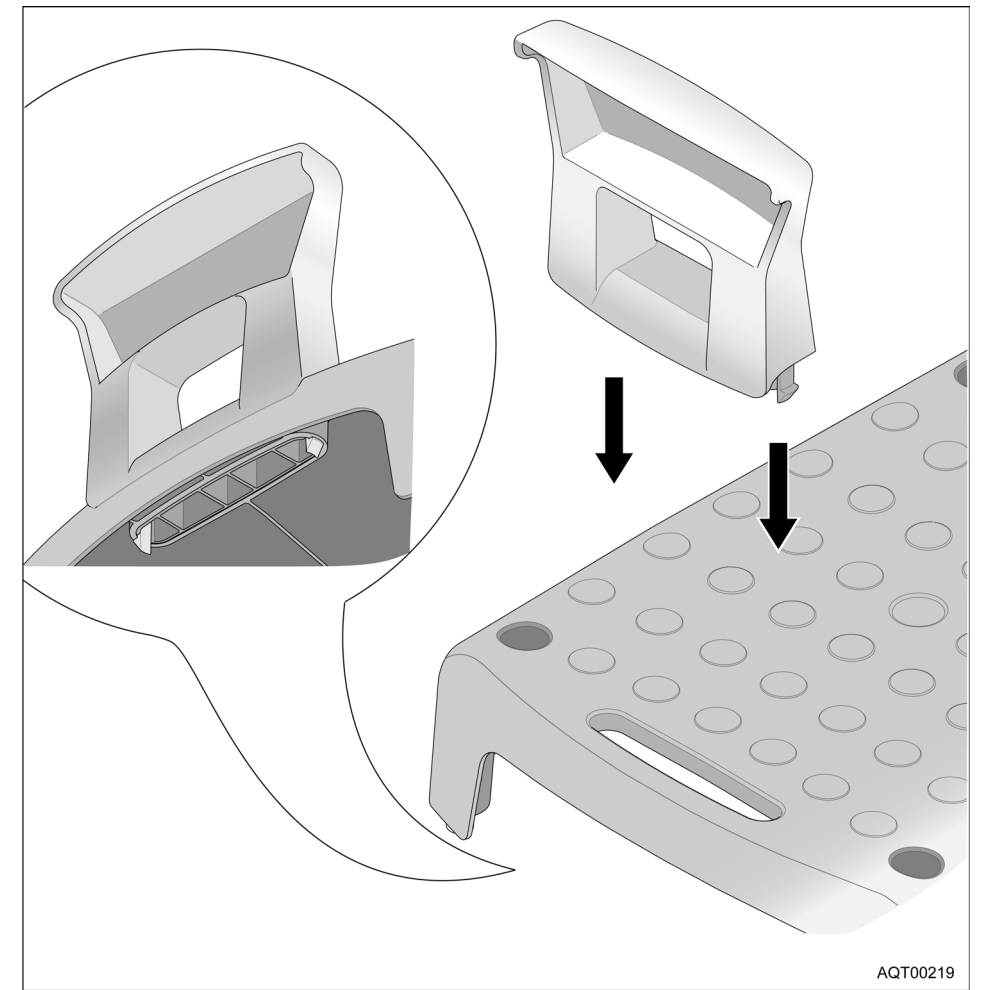
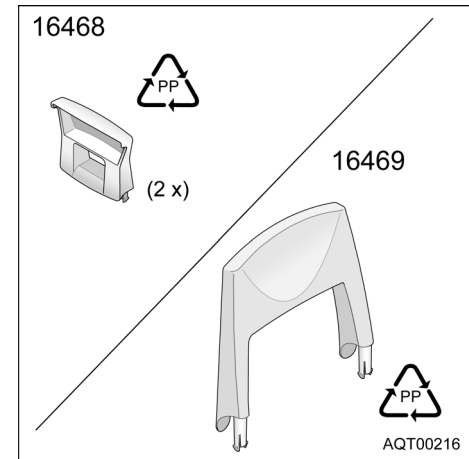
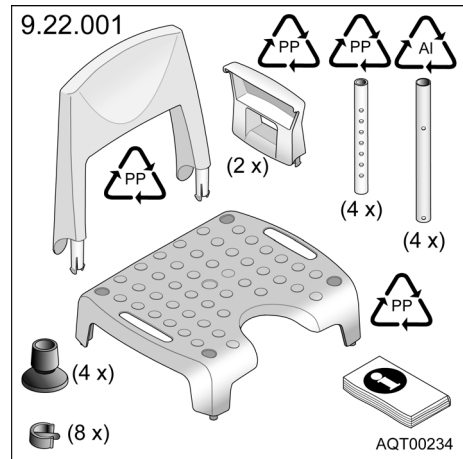
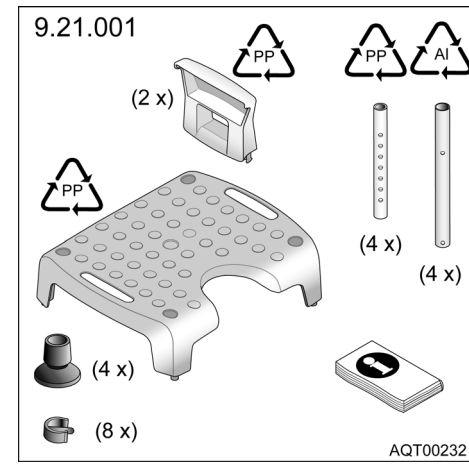
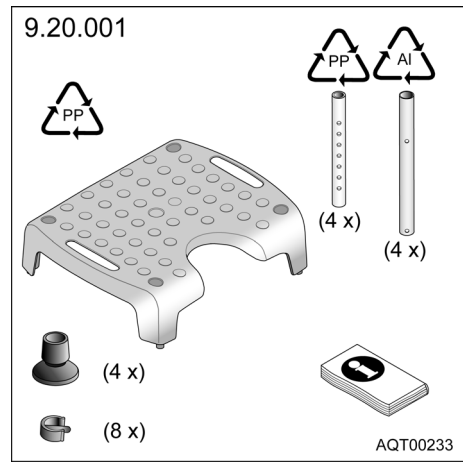

Montieren
 Mounting
 Montage
 Montaggio
 Montar
 Monteren
 Montering
 Asennus
 Montering
 Montering

